

Mått Serie ME/MS - Aluminium

Typ ME/MS	Montagemått fot					Axel						Övrigt						KK mm		
	A	B	C	H	K	D	E	F	G	ED	DH	AA	AB	BB	L	HA	AC		AD	HD
56	90	71	36	56	5.8	9	20	3	7.2		M3	110	195		120	110	155			1xM16
63	100	80	40	63	5.8	11	23	4	8.5		M4	120	215		130	115	165			1xM16
71	112	90	45	71	7	14	30	5	11		M5	132	240		145	125	185			1xM20
80	125	100	50	80	7	19	40	6	15.5		M6	160	290		165	135	215			1xM20
90S	140	100	56	90	10	24	50	8	20		M8	175	310		185	145	235			1xM20
90L	140	125	56	90	10	24	50	8	20		M8	175	335		185	145	235			1xM20
100	160	140	63	100	12	28	60	8	24		M10	196	368*		205	170	255			1xM20
112	190	140	70	112	12	28	60	8	24		M10	220	395		230	180	285			2xM25
132S	216	140	89	132	12	38	80	10	33		M12	252	436		270	193	325			2xM25
132M/L	216	178	89	132	12	38	80	10	33		M12	252	474		270	193	325			2xM25
160M	254	210	108	160	15	42	110	12	37		M16	290	640		320	230	390			2xM32
160L	254	254	108	160	15	42	110	12	37		M16	290	640		320	230	390			2xM32

* ME100LB-4 och MS 100LC har L = 387 mm

B3

Typ ME/MS	B5-fläns					
	M	N	P	S	T	LA
56	100	80	120	7	3	
63	115	95	140	10	3.0	9
71	130	110	160	10	3.5	8
80	165	130	200	12	3.5	10
90	165	130	200	12	3.5	12
100	215	180	250	15	4.0	14
112	215	180	250	15	4.0	14
132	265	230	300	15	4.0	13
160	300	250	350	19	5.0	15

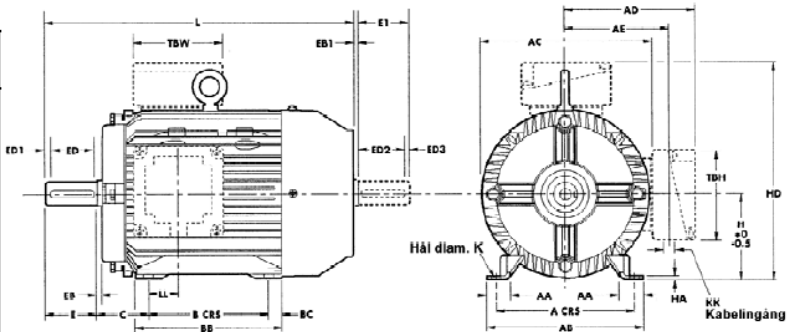

Typ ME/MS	B14-fläns				
	M	N	P	S	T
56	65	50	80	M5	2.5
63	75	60	90	M5	2.5
71	85	70	105	M6	2.5
80	100	80	120	M6	3.0
90	115	95	140	M8	3.0
100	130	110	160	M8	3.5
112	130	110	160	M8	3.5
132	165	130	200	M10	3.5
160	215	180	250	M10	3.5

B5, B3/B5

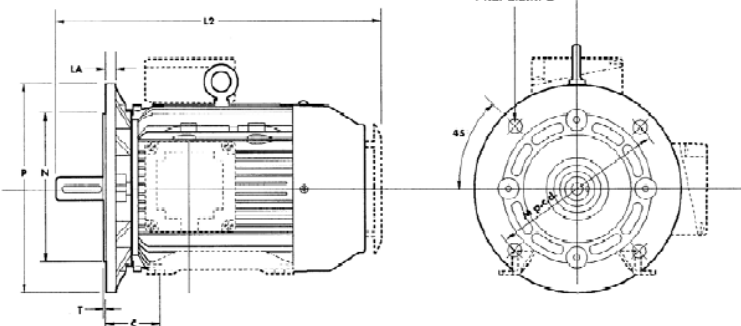

Typ ME/MS	B14medium-fläns				
	M	N	P	S	T
56	85	70	105	M6	2.5
63	100	80	120	M6	3.0
71	115	95	140	M8	3.0
80	130	110	160	M8	3.5
90	130	110	160	M8	3.5
100	165	130	200	M10	3.5
112	165	130	200	M10	3.5
132	215	180	250	M12	4
160	265	230	300	M12	4

B14, B3/B14

